

**CITY OF GRANTVILLE
CITY COUNCIL WORK SESSION MEETING AGENDA
January 13, 2020 at 6:30 p.m.
Glanton Municipal Complex
123 Lagrange Street, Grantville, GA**

Call to Order:

Invocation:

Pledge of Allegiance:

Approval of Agenda:

Discussion/Decision: Enterprise Fleet Management Program – Mr. Jabari Price

Election of Mayor Pro Tem: Election will take place on Thursday, January 23, 2020

Announcement of Committee Assignments by the Mayor

Announcement of Annual Strategic Planning Session on Saturday, February 15, 2020 at the Golden Creek Room, Coweta County Fairgrounds 8:30 a.m. to 4:00 p.m.

Discussion/Decision on Funding of the Removal of Sludge from the Land Application System Pond #1 Colley Street

Discussion/Decision on contract with WBI, Inc. and contracts with Crawford Grading and Pipeline, Inc. for the Sludge Removal from Pond #1 Colley Street

Discussion/Approval on Letter of Intent to Participate in Natural Gas Connection; One-stop shopping for appliance sales, installation and service for retail customers

Discussion/Approval on contract with Russell Masonry for repair of the Cemetery Retaining Wall

Discussion/Decision on the Schematic Design of the Passenger Depot – schematic design will be presented at the City Council meeting on Thursday, January 23, 2020

Discussion/Decision on Veto of Resolution Number 2019-27 Amending Section 2.02(f) of the Charter to Require Election of the Mayor and Council by Majority Vote

Discussion/Decision on Proposals to Repair and Resurface Basketball Courts:

- a. Basketball Court at Grantville Park Complex (Post Street): \$99,500.00**
- b. Basketball Court at 117 Meriwether Street: \$65,000.00**

Discussion/Decision on Proposal to Fence the Basketball Court at 117 Meriwether St: \$9,850.00

Discussion/Decision on Ad Hoc Budget Committee

Discussion/Decision on COLA increase for City Manager

Second Reading of Ordinance Number 2019-13 to Amend Section 38-1(b) of the Code of Ordinances to employ the services of a rating specialist not less than every five years to study and review the rates then in effect and suggest changes

Second Reading of Ordinance Number 2019-14 to Amend Section 3.03 of the Charter

Second Reading of Ordinance Number 2019-15 to Add a New Paragraph to Charter section 3.04

Second Reading of Ordinance Number 2019-16 to Amend Section 3.08 of the Charter

Citizens Comments:

City Council Comments

Councilmember Alan Wacaser:

Councilmember Mark King:

Councilmember Ruby Hines:

Councilmember Jim Sells:

Mayor Doug Jewell:

City Manager Al Grieshaber Jr.:

City Attorney Mark Mitchell:

Adjournment:

Dec.20, 2019

Robi Higgins
City Clerk
City of Grantville
123 LaGrange St.
Grantville , Ga. 30220

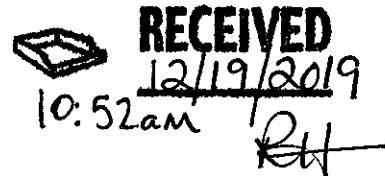
**RECEIVED**
12/19/2019
10:52am
RH

RE: Veto of Resolution 2019-27 Amending Section 1.04(t) of the Charter of the City of Grantville

Dear Ms. Higgins:

Pursuant to Section 2.06 of the Charter of the City of Grantville, I am Vetoing the above referenced and attached Resolution 2019-27 adopted by the city council Dec. 16, 2019 requesting introduction of local legislation in the 2020 session of the General Assembly to amend section 2.02(f) of the charter of the City Of Grantville, Ga.

My reason for this veto is as follows:

In my opinion the current requirement of a plurality of votes to elect is the best way to elect our Mayor and Council Members.

Yours truly,

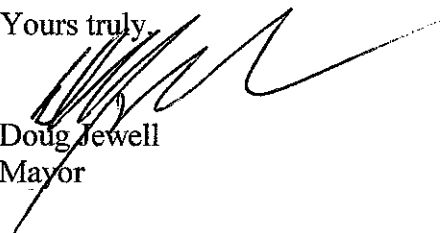
Doug Jewell
Mayor

cc: City Councilmembers
Al Grieshaber Jr. City Manager

RESOLUTION NO. 2019-27

**A RESOLUTION REQUESTING THE INTRODUCTION OF LOCAL LEGISLATION
IN THE 2020 SESSION OF THE GEORGIA GENERAL ASSEMBLY TO AMEND
SECTION 2.02(f) OF THE CHARTER OF THE CITY OF GRANTVILLE TO REQUIRE
ELECTION OF THE MAYOR AND COUNCIL BY MAJORITY VOTE**

WHEREAS, Section 1.04(t) of the Charter of the City of Grantville provides that the mayor and council have the authority and power: "To exercise and enjoy all powers, functions, rights, privileges and immunities necessary or desirable to promote or protect the safety, health, peace, security, good order, comfort, convenience, morals, and general welfare of the city and its inhabitants, and all implied powers necessary to carry into execution all powers granted in this Act as fully and completely as if such powers were fully enumerated herein, no enumeration of particular powers in this Act shall be held to be exclusive of others nor restrictive of general words and phrases granting powers, but shall be held to be an addition to such powers unless expressly prohibited to cities under the Constitution or applicable public acts of the state."; and

WHEREAS, Section 2.02 of the Charter of the City of Grantville provides that "Those candidates seeking election for the office of mayor and council who receive a plurality of the votes cast shall be deemed elected."; and

WHEREAS, it is desirable to promote or protect the safety, health, peace, security, good order, comfort, convenience, morals, and general welfare of the city and its inhabitants that the mayor and city council be required to receive a majority of the votes cast to be elected to office; and

WHEREAS, O.C.G.A. § 36-35-6(a)(1) provides that any action affecting the procedure for election of members to the municipal governing authority cannot be adopted by home rule, but shall instead be the subject of general law or local Acts of the General Assembly;

NOW, THEREFORE, BE IT RESOLVED by the City Council of the City of Grantville, Georgia, and it is hereby resolved that the City requests that its legislative delegation introduce and support in the 2020 legislative session the passage of such local Acts of the General Assembly as are necessary to amend the Charter of the City of Grantville so as to require that the mayor and city council receive a majority of the votes cast in a municipal election to be elected to office.

IT IS SO RESOLVED this _____ of December, 2019, by the City Council of the City of Grantville.

Mayor

Attest: _____
Clerk

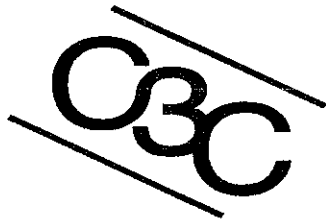

Dear City of Grantville,

Please accept these two proposals on behalf of Chord III contracting, LLC. The first proposal is for a full court renovation and new basketball goals at the Grantville Park basketball court. The second proposal is for renovating/fabricating a new playing surface at the 117 Meriwether Street slab. These two proposals are very similar to what we are currently doing for the City of Douglasville. In fact, what I am proposing at the Grantville Park site is almost identical to the four basketball courts we are currently demolishing and rebuilding for the City of Douglasville. I would be glad to meet with a representative to further explain our propositions if necessary. If our proposals are out of the Cities budget for these projects, I would be glad to work with the city to find other options that fit the budget. However, I feel that what I have proposed will yield the most value and quality to the City of Grantville. Please do not hesitate to reach out to me with any questions.

Sincerely,

Thomas Ogletree

Chief Operating Officer

Cell: 770-301-2463

Email: thomaso.c3c@gmail.com

CHORD III CONTRACTING, LLC.

8665 Baldwin Parkway • Douglasville, Georgia 30134 • O: 678.909.6996 • F: 678.540.8905

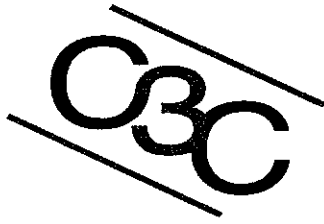

Basketball Court at Grantville Park

Scope of Work:

- Demo and haul off entire existing concrete slab court and 2 existing basketball goals
- Grade proposed court area to a level and compacted grade
- Install 4" of GAB/ crusher run gravel base on the graded area of the proposed new slab
- Form area of 60'X100' with wooden forms on proposed new slab area
- Install 11 mil vapor barrier plastic inside of formed area
- Install 6-gauge W.W.F. sheets on top of vapor barrier inside of formed area
- Pour a 4" thick slab in the 60'X100' formed area
- Concrete to be 3,000 PSI with appropriate sand, aggregate, cement, and water mixture. – Concrete to be supplied by a local ready-mix supplier – On site mixing methods will NOT be used
- Install 2 LS-200 basketball goals manufactured by Jaypro sports at each end of the court
- Paint and stripe court with basketball court markings – Colors of paint markings to be chosen by the City of Grantville
- Strip forms from the poured slab
- Clean up/dress up site area to leave the project owner with a neat and clean final product

Total Proposed Project Cost: \$99,500.00

CHORD III CONTRACTING, LLC.

8665 Baldwin Parkway • Douglasville, Georgia 30134 • O: 678.909.6996 • F: 678.540.8905

Grantville Park

Demoilition Plan

Drawing NOT to scale

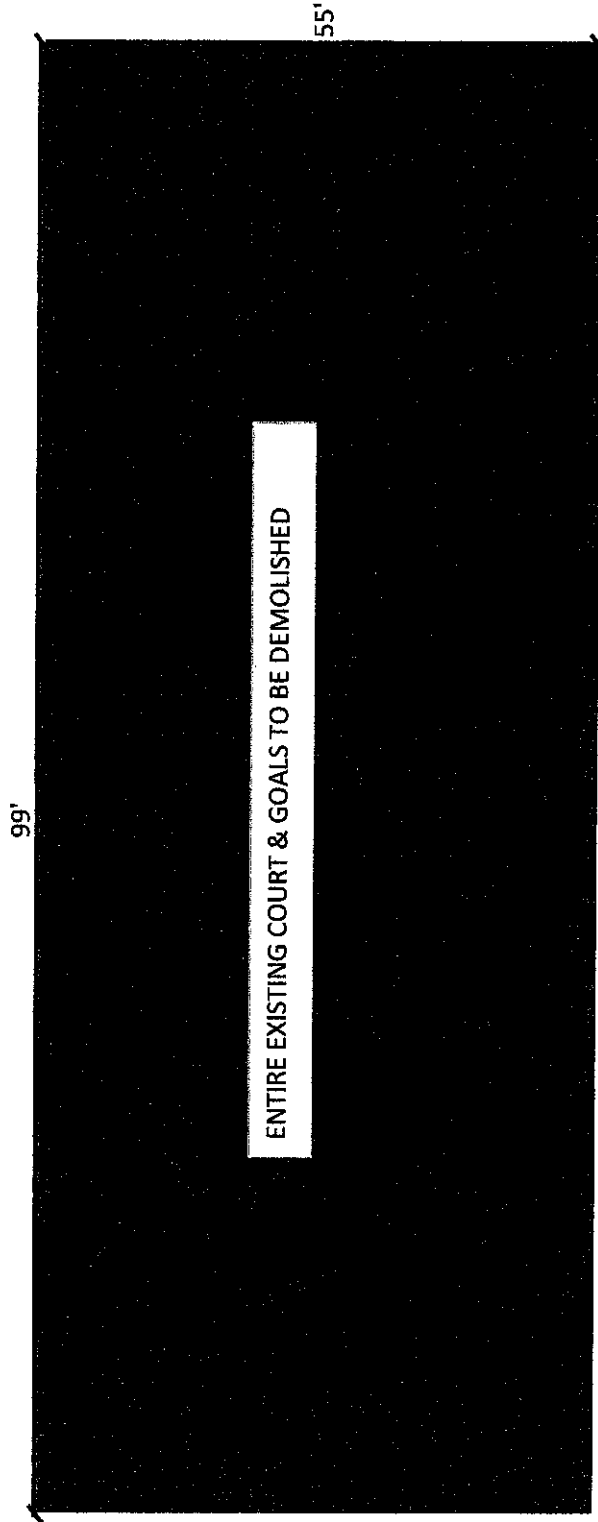

Grantville Park

Construction Plan

Drawing NOT to scale

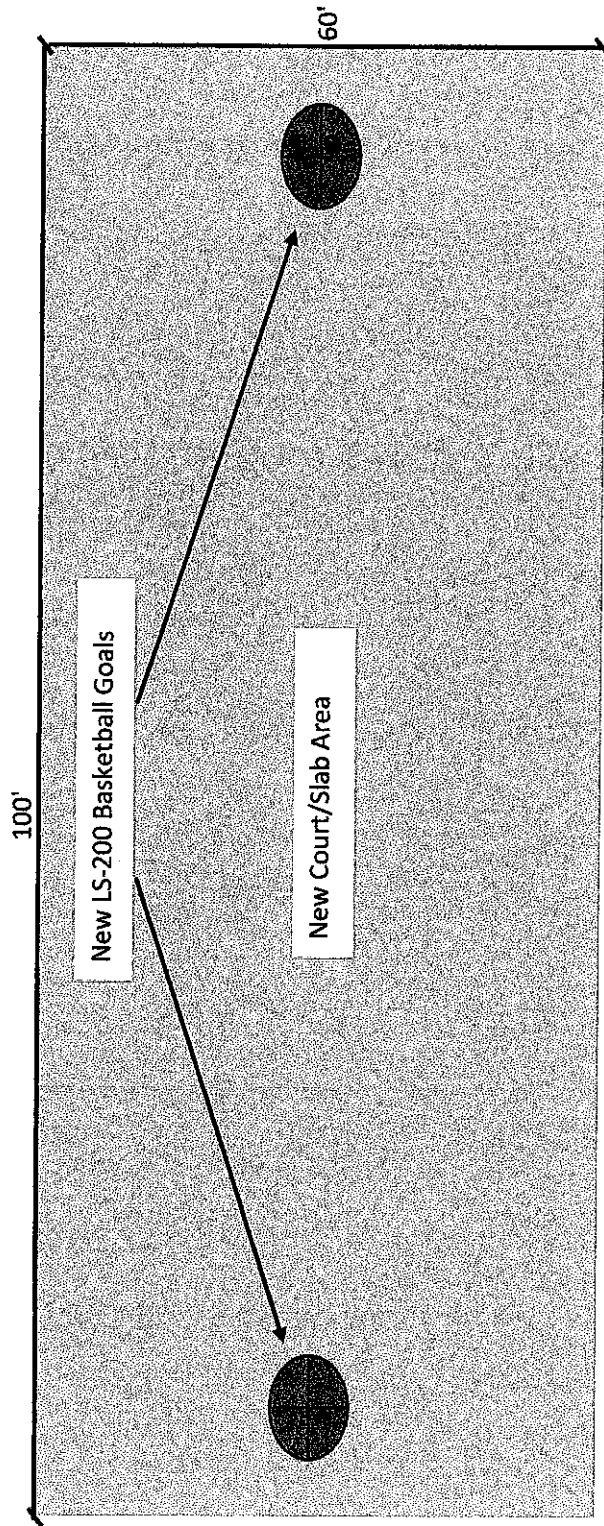

LS-200 / LS-200RS

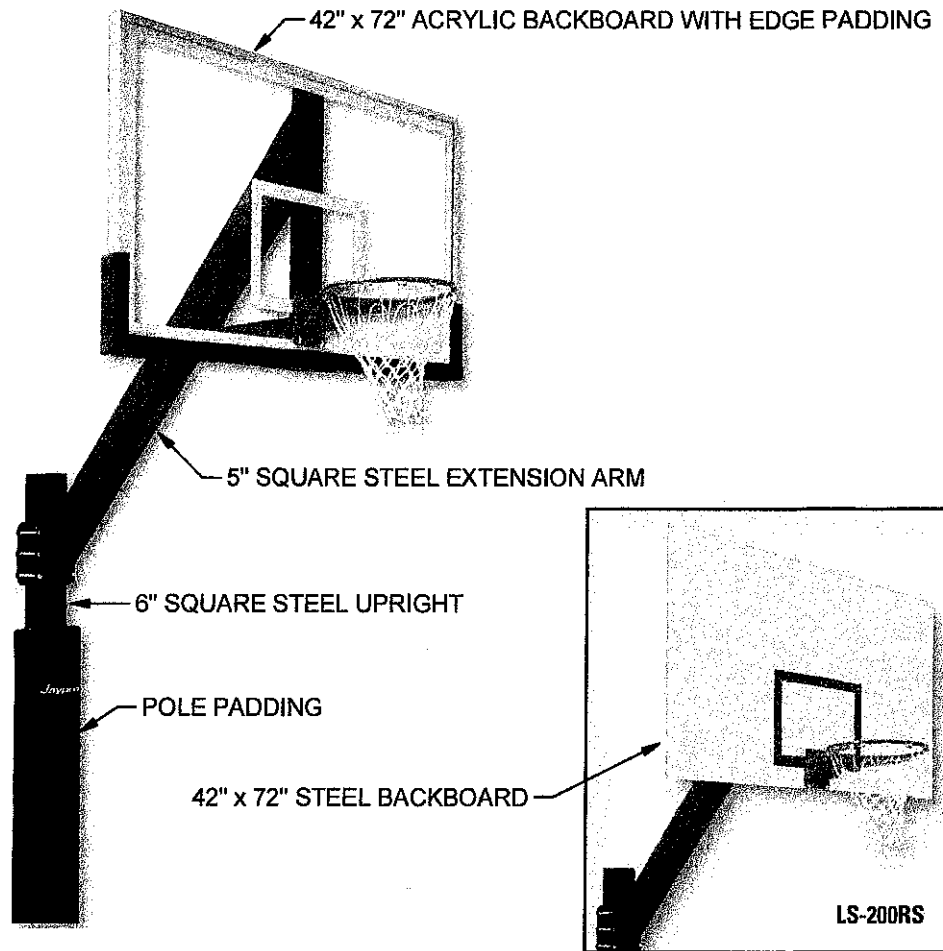

FEATURES:

- * 66" PLAY SAFE AREA
- * UPRIGHT & EXTENSION ARM ARE CONSTRUCTED OUT OF HEAVY GAUGE STEEL.
- * FIXED HEIGHT OF 10' HIGH RIM, HEIGHT CAN BE ADJUSTED AFTER COURT RESURFACING.
- * OFFICIAL SIZE BACKBOARD 42" x 72" ACRYLIC OR STEEL BOARD.
- * LS-200 COMES WITH ACRYLIC BACKBOARD WITH EDGE PADDING.
- * LS-200RS COMES WITH STEEL BACKBOARD.

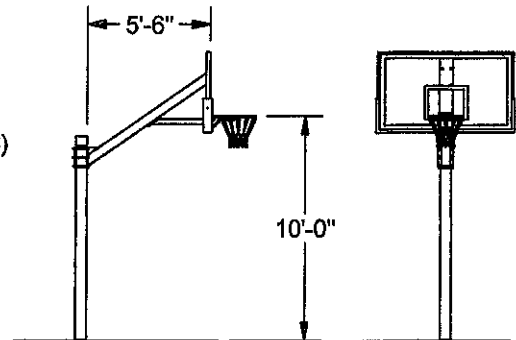
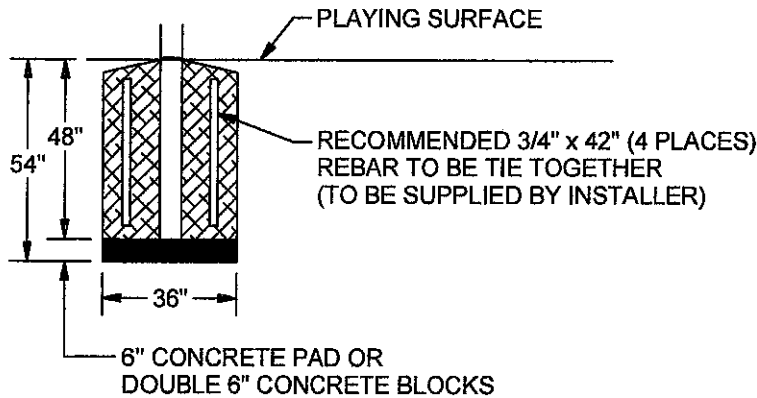

REV.	DESCRIPTION	DATE	BY
-	INITIAL	1/12	Moune T.

COPYRIGHT 2008
JAYPRO SPORTS, LLC.
ALL RIGHTS RESERVED

LS-200 / LS-200RS

THIS PRINT IS THE PROPERTY OF JAYPRO SPORTS, LLC.
AND MAY NOT BE REPRODUCED WITHOUT WRITTEN PERMISSION

www.jaypro.com

FAX: 860.444.1779 (SALES)
860.440.0626 (ENG.)

PHONE: 800.243.0533 (TOLL FREE)
860.447.3001 (LOCAL)

JAYPRO SPORTS, LLC, 976 HARTFORD TURNPIKE, WATERFORD, CT 06385 USA

DRAWING NAME / PART NUMBER:	
LS-200 / LS-200RS	
DRAWN BY:	ISSUE DATE:
Moune T.	1/18/2012
CHKD BY:	CHK DATE:
WVB	1/18/2012
SHEET:	REV.
1 OF 1	-



Basketball Court at 117 Meriwether Street

Scope of Work:

- Demo and haul off approximately 50'X30' area of the existing court area at the top right end of the court from the street view
- Grade, level, and compact new proposed court area
- Install 4" of GAB/Crusher run gravel base on the graded area of the proposed new slab
- Form an area of 64'X46.5' with wooden forms on proposed new slab area
- Install 11 mil vapor barrier plastic inside of formed area
- Pour a 4" thick slab in the 64'X46.5' formed area
- Concrete to be 3,000 PSI with appropriate sand, aggregate, cement, and water mixture – concrete to be supplied by a local ready-mix supplier – On site mixing methods will NOT be used
- Install 2 LS-200 basketball goals manufactured by Jaypro Sports at each end of the court
- Paint and stripe court with basketball court markings – Colors of paint to be chosen by the City of Grantville
- Strip forms from the poured slab
- Clean up/dress up site area to leave the project owner with a neat and clean final product

Total Proposed Project Cost: \$65,000.00

CHORD III CONTRACTING, LLC.

8665 Baldwin Parkway • Douglasville, Georgia 30134 • O: 678.909.6996 • F: 678.540.8905

117 Meriwether Street

Demolition Plan

NOTE: Drawing not to scale

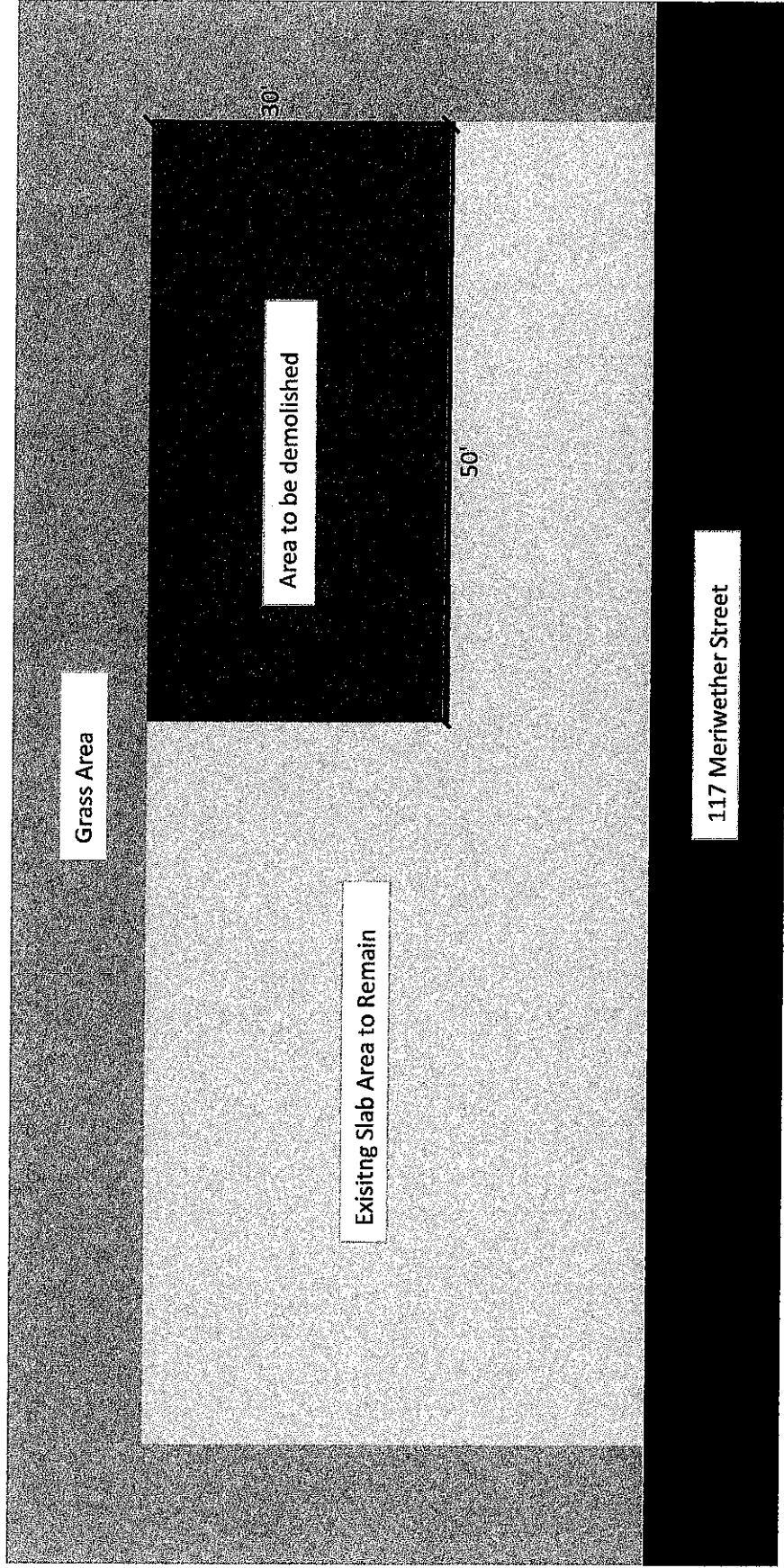

117 Meriwether Street

Construction Drawings

Drawings NOT to scale

New LS-200 Basketball Goals

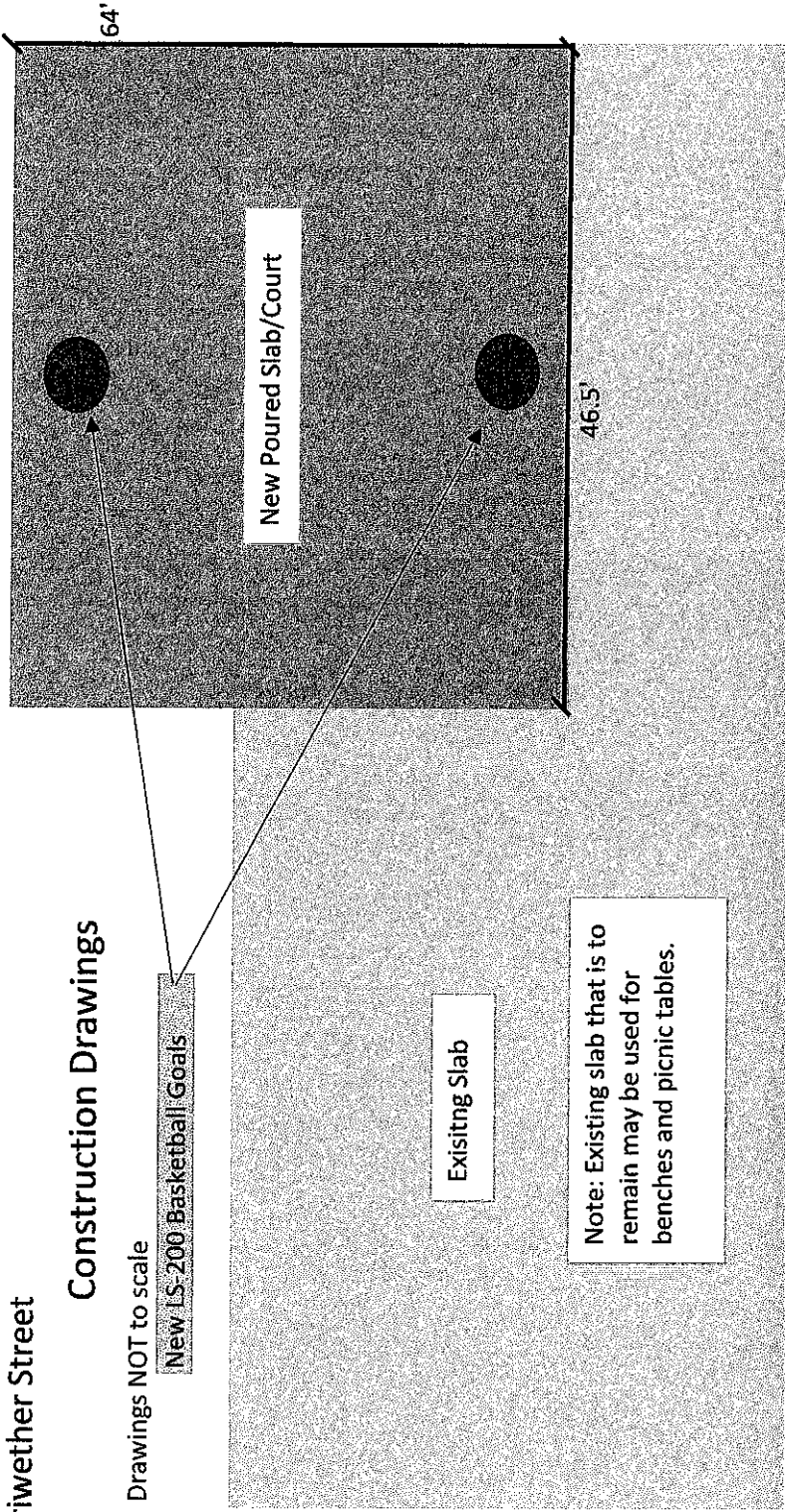

117 Meriwether Street

**CITY OF GRANTVILLE
AD HOC BUDGET COMMITTEE
OCTOBER 28, 2019**

COUNCIL MEMBERS:

1 -

2 -

~~3 -~~

RESIDENTS:

1 - Mary Elder

2 - Connie Warren

3 - Trellis Zackery

4 -

5 -

Memorandum

To: Mayor and City Council Members

From: City Manager

Subject: 2% COLA Increase Effective October 1, 2019

As you may recall, the Fiscal Year 2019-2020 General Fund budget contained a Cost of Living Allowance (COLA) of 2% for all employees.

Section 7: Benefits of the Employment Agreement of the City Manager in Subsection B. provides that "Except as otherwise provided herein, the Manager shall accrue all other benefits at the same level as other employees of the City.

However, Section 6: Compensation in Subsection B. provides that "The Manager may be provided with such additional or further compensation above the base salary as may be voted by the City Council from time to time based upon its annual performance evaluation and review of the Manager, but such addition or further annual compensation shall not be less than the average across the board increase granted to other City employees."

Therefore, although the Fiscal Year 2019-2020 General Fund budget was adopted by a majority vote of the City Council, the City Manager, with an abundance of caution, requests that a vote be taken on the 2% COLA increase retroactive to October 1, 2019.

ORDINANCE NUMBER 2019-13

**AN ORDINANCE BY THE CITY OF GRANTVILLE, GEORGIA
TO AMEND CHAPTER 38, ARTICLE I, SECTION 38-1 OF THE CODE OF ORDINANCES TO
ESTABLISH THE TITLE OF THE SECTION AS MANDATORY RATE REVIEW AND TO
ESTABLISH THAT THE CITY SHALL CONDUCT A REVIEW AND STUDY OF ITS UTILITY
RATES NOT LESS THAN EVERY FIVE YEARS AND FOR OTHER PURPOSES**

WHEREAS, the Mayor and City Council of the City of Grantville are charged with safeguarding the safety, health and welfare of the citizens of the City, and

WHEREAS, Section 1.04(h) of the Charter of the City of Grantville provides that the Mayor and City Council are empowered to regulate the rates and services of public utilities,

NOW THEREFORE, be it ordained by the Mayor and City Council of the City of Grantville, Georgia, and it is hereby ordained by the authority of the same that the following ordinance is hereby adopted:

Section 1:

Section 38-1. Mandatory annual rate review is deleted in its entirety, and replaced as follows:

Sec. 38-1. Mandatory rate review.

- (a) The elected officials of the city shall pass on to any and all utility customers any increase from any supplier of water, gas and electric and such increases shall be automatic and effective without action of council. The city clerk shall charge the rates with the first billing cycle after such an increase.
- (b) The governing body of the city shall employ the services of a rating specialist not less than every five (5) years to study and review the utility rates then in effect and suggest changes, either increases or decreases, in each utility offered to the citizens.
- (c) At a regular council meeting, the recommendations of the rate study shall be made public and if such recommended rates of the study are not adopted, a full explanation shall be given at such meeting as to why such recommendations of the rating specialist are not being put into effect.

Section 2: Repealer

All ordinances or parts of ordinances in conflict with this ordinance are repealed.

First Reading: _____

SO ORDAINED in lawfully assembled open session this ____ day of _____, 2020.

MAYOR

Attest: _____
Clerk

ORDINANCE NUMBER 2019-14

**AN ORDINANCE TO AMEND SECTION 3.03 OF THE CHARTER OF THE
CITY OF GRANTVILLE, GEORGIA**

WHEREAS, in accordance with the home rule power of O.C.G.A. § 36-35-3, the Mayor and the City Council of the City of Grantville, Georgia, finds that it is in the best interest of the public health, safety and welfare to amend the Charter of the City of Grantville by amending Section 3.03;

NOW, THEREFORE, be it ordained that Section 3.03 of the Charter of the City of Grantville, Georgia is hereby amended as follows:

Section 3.03 Administrative duties of mayor.

The Mayor shall be the executive head of the city government responsible for the efficient and orderly administration of the city's affairs. He shall be responsible for the enforcement of laws, rules and regulations, ordinances, and for franchises in the city and the city attorney shall take such legal actions as the Mayor may direct for such purposes. Should the post of City Manager not be filled, he shall have the authority to control the work of all offices and employees of the city and shall further have the authority to relieve any employee of his duties without pay for up to seven (7) days for failure to properly perform those duties or for failure to follow lawful instructions. The Mayor shall submit to the Council annual budgets, reports and such other information as he may deem necessary or the Council may require. He shall have authority to make allotments of funds within the limits of appropriations and no expenditures shall be made without his approval. If no other employee or official is designated as purchasing agent, he shall act as purchasing agent for the city. He may conduct inquiries and investigations into conduct of the city's affairs and shall have such other powers and duties as may be provided by Ordinance not inconsistent with this act.

FIRST READING: _____ day of _____, 20__.

SO ORDAINED in lawfully assembled open session this _____ day of _____, 20__.

MAYOR

Attest: _____
Clerk

ORDINANCE NUMBER 2019-15

**ORDINANCE TO AMEND SECTION 3.04 OF THE CHARTER OF THE CITY
OF GRANTVILLE, GEORGIA**

WHEREAS, in accordance with the home rule power of O.C.G.A. § 36-35-3, the Mayor and the City Council of the City of Grantville, Georgia, finds that it is in the best interest of the public health, safety and welfare to amend the Charter of the City of Grantville by amending Section 3.04;

NOW, THEREFORE, be it ordained that Section 3.04 of the Charter of the City of Grantville, Georgia is hereby amended by adding the following to section 3.04:

The city manager shall notify the mayor and city council, as soon as feasible, of all work being performed on city property save for ordinary repair and maintenance activities, identifying who is performing the work and the funding source for such work.

FIRST READING: ____ day of _____, 20__.

SO ORDAINED in lawfully assembled open session this ____ day of _____, 20__.

MAYOR

Attest: _____
Clerk

ORDINANCE NUMBER 2019-16

**ORDINANCE TO AMEND SECTION 3.08 OF THE CHARTER OF THE CITY
OF GRANTVILLE, GEORGIA**

WHEREAS, in accordance with the home rule power of O.C.G.A. § 36-35-3, the Mayor and the City Council of the City of Grantville, Georgia, finds that it is in the best interest of the public health, safety and welfare to amend the Charter of the City of Grantville by amending Section 3.08;

NOW, THEREFORE, be it ordained that Section 3.08 of the Charter of the City of Grantville, Georgia is hereby amended as follows:

Section 3.08 Personnel policies.

All employees serve at will and may be removed from office at any time by the City Manager, if the post is filled, or otherwise by the Mayor and city council unless otherwise provided by ordinance. The council shall adopt rules and regulations consistent with this charter concerning:

- (1) The method of employee selection and probationary periods of employment;
- (2) The administration of any position classification and pay plan, methods of promotion and application of service ratings thereto, and transfer of employees within the classification plan;
- (3) Hours of work, vacation, sick leave, and other leaves of absence, overtime pay, and the order and manner in which layoff shall be effected; and
- (4) Such other personnel policies as may be necessary to provide for adequate and systematic handling of the personnel affairs of the City of Grantville.

FIRST READING: ____ day of _____, 20__.

SO ORDAINED in lawfully assembled open session this ____ day of _____, 20__.

MAYOR

Attest: _____
Clerk